

MOUNT BRAKE/CLUTCH MOUNT



SKU CODE	QLM-CLH
BARCODE (EAN-13)	9348943055383
MSRP	US \$59.99 AU \$84.95 CA \$79.99 EU €59.99 UK £54.99
MANUFACTURED IN	China
HS CODE	392630
HTS CODE (USA)	3926305000
PRIMARY APPLICATIONS	MOTORCYCLE

PRODUCT DETAILS

FEATURES

- Compact design with twin bolt mounting to the brake/clutch handlebar clamp
- Mount base hole pitch range from 32 - 38mm
- Inboard single screw adjustment with angle and pivot adjustment towards the rider field of view
- Index lever head is offset inboard away from the handlebar controls
- Non-handed and can be mounted on the left hand or right hand side of the brake/clutch handlebar clamp on a motorbike
- High tensile fasteners including serrated flange bolts for the brake/clutch handlebar clamp for added security
- Anodised black die-cast base
- Microencapsulated thread locking fasteners

ADJUSTABILITY

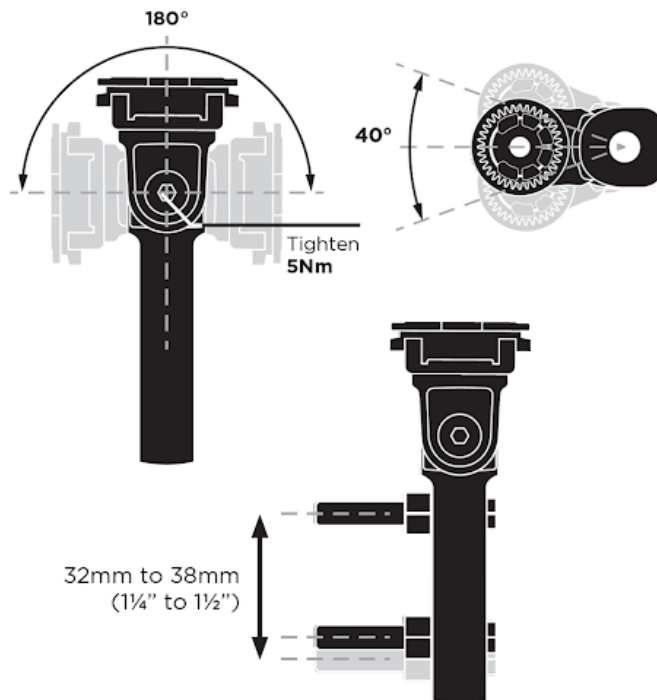

COMPATIBILITY

Compatible with:
 All Quad Lock Cases
 Quad Lock Vibration Dampener (QLA-VDM)
 Quad Lock Weatherproof Wireless Charging Heads (QLA-MOT-WCH-3)

INCLUDED IN BOX	1 x Brake/Clutch Mount 2 x M6 x 45 serrated flange bolts with thread locker 2 x UNC 1/4"-20 x 1.75 serrated flange bolts with thread locker 2 x Spacers 1 x Combination 3mm/4mm Hex Key
MEASUREMENTS	35mm L x 50mm W x 98mm H
MATERIALS	Base - Anodised die cast aluminium Index head, knuckle and pivot spacer - GF33% Nylon Pivot pins, threaded Inserts - SS Fasteners - High tensile steel with ND593S threadlocker
PRODUCT WEIGHT	120 gms

PRODUCT DETAILS	INDIVIDUAL	INNER CARTON	MASTER CARTON
QTY	-	10 Units	50 Units
SKU CODE	QLM-CLH	10QLM-CLH	50QLM-CLH
BARCODE	9348943055383	19348943055380	29348943055387
DIMENSIONS (L x W x H)	3.8 x 6.5 x 9 cm	45 x 7.3 x 12 cm	46.5 x 39 x 14 cm
WEIGHT	0.19kg	1.97kg	10.43kg

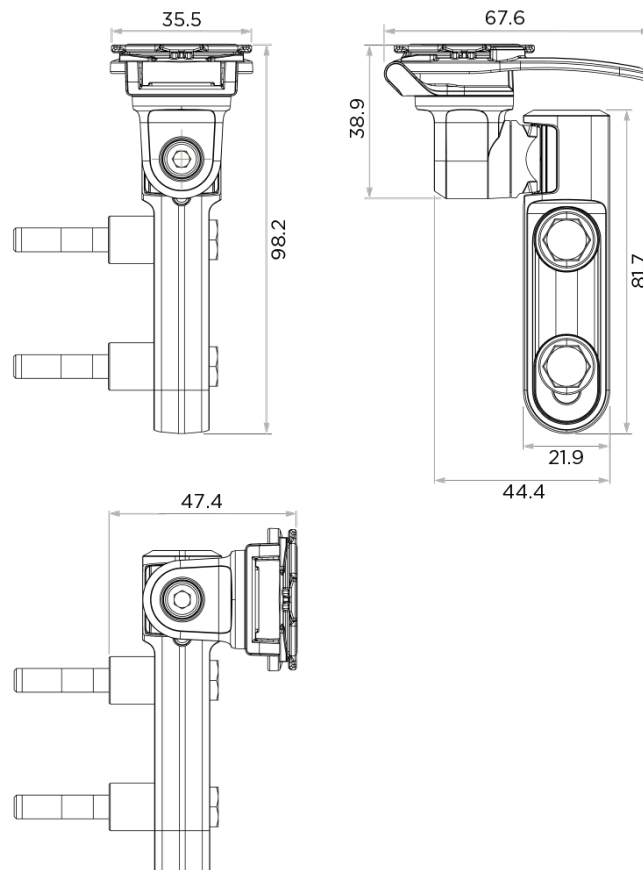

All dimensions in mm



©2023 QUAD LOCK Pty Ltd
Designed in Melbourne, AUS | Made in China | All Rights Reserved
All trademarks are property of their prospective owners

Head Office: Suite 6A, Level 3, The Como Centre,
299 Toorak Rd, South Yarra, VIC 3141, Australia

QUADLOCKCASE.NET